

# Panasonic

## Installation Guide

### Network Video Encoder

Model No. **WJ-GXE500**

**WJ-GXE500E**

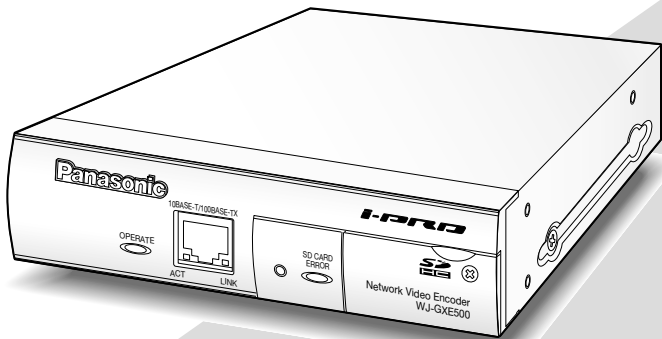

Before attempting to connect or operate this product, please read these instructions carefully and save this manual for future use.

The model number is abbreviated in some descriptions in this manual.

## WARNING:

- Apparatus shall be connected to a mains socket outlet with a protective earthing connection.
- The mains plug or an appliance coupler shall remain readily operable.
- To prevent fire or electric shock hazard, do not expose this apparatus to rain or moisture.
- The apparatus should not be exposed to dripping or splashing and that no objects filled with liquids, such as vases, should be placed on the apparatus.
- All work related to the installation of this product should be made by qualified service personnel or system installers.
- For PERMANENTLY CONNECTED APPARATUS provided neither with an all-pole MAINS SWITCH nor an all-pole circuit breaker, the installation shall be carried out in accordance with all applicable installation rules.
- The connections should comply with local electrical code.

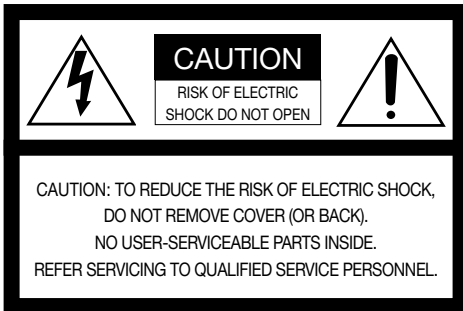

The lightning flash with arrow-head symbol, within an equilateral triangle, is intended to alert the user to the presence of uninsulated "dangerous voltage" within the product's enclosure that may be of sufficient magnitude to constitute a risk of electric shock to persons.



The exclamation point within an equilateral triangle is intended to alert the user to the presence of important operating and maintenance (servicing) instructions in the literature accompanying the appliance.

Power disconnection. Unit with or without ON-OFF switches have power supplied to the unit whenever the power cord is inserted into the power source; however, the unit is operational only when the ON-OFF switch is in the ON position. Unplug the power cord to disconnect the main power for all units.

We declare under our sole responsibility that the product to which this declaration relates is in conformity with the standards or other normative documents following the provisions of Directives 2006/95/EC and 2004/108/EC.

Wir erklären in alleiniger Verantwortung, daß das Produkt, auf das sich diese Erklärung bezieht, mit den folgenden Normen oder normativen Dokumenten übereinstimmt. Gemäß den Bestimmungen der Richtlinie 2006/95/EC und 2004/108/EC.

Nous déclarons sous notre propre responsabilité que le produit auquel se réfère la présente déclaration est conforme aux normes spécifiées ou à tout autre document normatif conformément aux dispositions des directives 2006/95/CE et 2004/108/CE.

Nosotros declaramos bajo nuestra única responsabilidad que el producto a que hace referencia esta declaración está conforme con las normas u otros documentos normativos siguiendo las estipulaciones de las directivas 2006/95/CE y 2004/108/CE.

Noi dichiariamo sotto nostra esclusiva responsabilità che il prodotto a cui si riferisce la presente dichiarazione risulta conforme ai seguenti standard o altri documenti normativi conformi alle disposizioni delle direttive 2006/95/CE e 2004/108/CE.

Wij verklaren als enige aansprakelijke, dat het product waarop deze verklaring betrekking heeft, voldoet aan de volgende normen of andere normatieve documenten, overeenkomstig de bepalingen van Richtlijnen 2006/95/EC en 2004/108/EC.

Vi erklærer os eneansvarlige for, at dette produkt, som denne deklaration omhandler, er i overensstemmelse med standarder eller andre normative dokumenter i følge bestemmelsene i direktivene 2006/95/EC og 2004/108/EC.

Vi deklarerar härmed vårt fulla ansvar för att den produkt till vilken denna deklaration hänvisar är i överensstämmelse med de standarder eller andra normativa dokument som framställs i direktiv nr 2006/95/EC och 2004/108/EC.

Ilmoitamme yksinomaisella vastuullamme, että tuote, jota tämä ilmoitus koskee, noudattaa seuraavia standardeja tai muita ohjeellisia asiakirjoja, jotka noudattavat direktiivien 2006/95/EC ja 2004/108/EC säädotksiä.

Vi erklærer oss alene ansvarlige for at produktet som denne erklæringen gjelder for, er i overensstemmelse med følgende normer eller andre normgivende dokumenter som følger bestemmelsene i direktivene 2006/95/EC og 2004/108/EC.

# Contents

Important safety instructions.....	4
Limitation of liability.....	5
Disclaimer of warranty.....	5
Preface .....	5
Main functions.....	6
About the user manuals .....	7
System requirements for a PC .....	7
Trademarks and registered trademarks.....	8
Copyright.....	8
Network security .....	9
Precautions .....	10
Precautions for Installation.....	12
Major operating controls and their functions .....	14
Rack mounting .....	16
Insert/remove an SDHC/SD memory card .....	18
Connection.....	20
Performing the network settings .....	25
Troubleshooting.....	27
Specifications.....	28
Standard accessories.....	30

For U.S.A

NOTE: This equipment has been tested and found to comply with the limits for a Class A digital device, pursuant to Part 15 of the FCC Rules. These limits are designed to provide reasonable protection against harmful interference when the equipment is operated in a commercial environment. This equipment generates, uses, and can radiate radio frequency energy and, if not installed and used in accordance with the instruction manual, may cause harmful interference to radio communications.

Operation of this equipment in a residential area is likely to cause harmful interference in which case the user will be required to correct the interference at his own expense.

FCC Caution: To assure continued compliance, (example - use only shielded interface cables when connecting to computer or peripheral devices). Any changes or modifications not expressly approved by the party responsible for compliance could void the user's authority to operate this equipment.

For Canada

This Class A digital apparatus complies with Canadian ICES-003.

For U.S.A

The serial number of this product may be found on the surface of the unit.

You should note the model number and serial number of this unit in the space provided and retain this book as a permanent record of your purchase to aid identification in the event of theft.

Model No. \_\_\_\_\_

Serial No. \_\_\_\_\_

## Important safety instructions

- 1) Read these instructions.
- 2) Keep these instructions.
- 3) Heed all warnings.
- 4) Follow all instructions.
- 5) Do not use this apparatus near water.
- 6) Clean only with dry cloth.
- 7) Do not block any ventilation openings. Install in accordance with the manufacturer's instructions.
- 8) Do not install near any heat sources such as radiators, heat registers, stoves, or other apparatus (including amplifiers) that produce heat.
- 9) Do not defeat the safety purpose of the polarized or grounding-type plug. A polarized plug has two blades with one wider than the other. A grounding type plug has two blades and a third grounding prong. The wide blade or the third prong are provided for your safety. If the provided plug does not fit into your outlet, consult an electrician for replacement of the obsolete outlet.
- 10) Protect the power cord from being walked on or pinched particularly at plugs, convenience receptacles, and the point where they exit from the apparatus.
- 11) Only use attachments/accessories specified by the manufacturer.
- 12) Use only with the cart, stand, tripod, bracket, or table specified by the manufacturer, or sold with the apparatus. When a cart is used, use caution when moving the cart/apparatus combination to avoid injury from tip-over.



- 13) Unplug this apparatus during lightning storms or when unused for long periods of time.
- 14) Refer all servicing to qualified service personnel. Servicing is required when the apparatus has been damaged in any way, such as power-supply cord or plug is damaged, liquid has been spilled or objects have fallen into the apparatus, the apparatus has been exposed to rain or moisture, does not operate normally, or has been dropped.

## Limitation of liability

THIS PUBLICATION IS PROVIDED "AS IS" WITHOUT WARRANTY OF ANY KIND, EITHER EXPRESS OR IMPLIED, INCLUDING BUT NOT LIMITED TO, THE IMPLIED WARRANTIES OF MERCHANTABILITY, FITNESS FOR ANY PARTICULAR PURPOSE, OR NON-INFRINGEMENT OF THE THIRD PARTY'S RIGHT.

THIS PUBLICATION COULD INCLUDE TECHNICAL INACCURACIES OR TYPOGRAPHICAL ERRORS. CHANGES ARE ADDED TO THE INFORMATION HEREIN, AT ANY TIME, FOR THE IMPROVEMENTS OF THIS PUBLICATION AND/OR THE CORRESPONDING PRODUCT (S).

## Disclaimer of warranty

IN NO EVENT SHALL Panasonic Corporation BE LIABLE TO ANY PARTY OR ANY PERSON, EXCEPT FOR REPLACEMENT OR REASONABLE MAINTENANCE OF THE PRODUCT, FOR THE CASES, INCLUDING BUT NOT LIMITED TO BELOW:

- (1) ANY DAMAGE AND LOSS, INCLUDING WITHOUT LIMITATION, DIRECT OR INDIRECT, SPECIAL, CONSEQUENTIAL OR EXEMPLARY, ARISING OUT OF OR RELATING TO THE PRODUCT;
- (2) PERSONAL INJURY OR ANY DAMAGE CAUSED BY INAPPROPRIATE USE OR NEGLIGENT OPERATION OF THE USER;
- (3) UNAUTHORIZED DISASSEMBLE, REPAIR OR MODIFICATION OF THE PRODUCT BY THE USER;
- (4) INCONVENIENCE OR ANY LOSS ARISING WHEN IMAGES ARE NOT DISPLAYED, DUE TO ANY REASON OR CAUSE INCLUDING ANY FAILURE OR PROBLEM OF THE PRODUCT;
- (5) ANY PROBLEM, CONSEQUENTIAL INCONVENIENCE, OR LOSS OR DAMAGE, ARISING OUT OF THE SYSTEM COMBINED BY THE DEVICES OF THIRD PARTY;
- (6) ANY CLAIM OR ACTION FOR DAMAGES, BROUGHT BY ANY PERSON OR ORGANIZATION BEING A PHOTOGENIC SUBJECT, DUE TO VIOLATION OF PRIVACY WITH THE RESULT OF THAT SURVEILLANCE-CAMERA'S PICTURE, INCLUDING SAVED DATA, FOR SOME REASON, BECOMES PUBLIC OR IS USED FOR THE PURPOSE OTHER THAN SURVEILLANCE;
- (7) LOSS OF REGISTERED DATA CAUSED BY ANY FAILURE.

## Preface

The network video encoder WJ-GXE500 or WJ-GXE500E (hereinafter, the unit) is designed to operate using a PC on a network (10BASE-T/100BASE-TX).

The unit can also capture images from up to 4 analog cameras and compress the images in JPEG, MPEG-4 or H.264 files.

By connecting to a network (LAN) or the Internet, images and audio from the unit can be monitored on a PC via a network. (Audio function is available only for images from Ch1.)

---

**Note:**

- It is necessary to configure the network settings of the PC and its network environment to monitor images and audio from the unit on the PC. It is also necessary to install a web browser on the PC.
- 

## Main functions

### **Motion adaptive interlace/progressive conversion function**

It is possible to generate digital images with smooth movements by detecting moving areas to process analog images.

### **Coaxial communication with cameras**

This unit can control the pan/tilt heads and lenses of optional combination cameras with the coaxial communication.

### **Cable compensation**

This unit compensates the deterioration of analog images caused by long-distance transmission to maintain the image clearness.

### **Power over Ethernet function**

When connecting with a PoE (Power over Ethernet) device, power will be supplied by simply connecting a LAN cable. (IEEE802.3afcompliant)

### **Interactive communication with audio is available (Only for images from Ch1)**

By using the audio output connector and the microphone input connector, receiving audio from the unit on a PC and transmitting audio from the PC to the unit is available.

### **SDHC/SD memory card slot equipped**

The images at alarm occurrence or network failure can be saved on an SDHC/SD memory card (option). Images can be directly saved on an SDHC/SD memory card. The images on an SDHC/SD memory card can be reproduced on a web browser or downloaded via a web browser. (Recommended SDHC/SD memory card  page 30)

### **RS-485 command table**

This unit can support RS-485 commands in various formats by uploading a command table to the unit.

## About the user manuals

There are 2 sets of operating instructions for the WJ-GXE500 (NTSC model), WJ-GXD500E (PAL model) as follows.

- Installation Guide: Explains how to install and connect devices.
- Operating Instructions (PDF): Explains how to perform the settings and how to operate this unit.

Adobe® Reader® is required to read these operating instructions (PDF) on the provided CD-ROM. When the Adobe® Reader® is not installed on the PC, download the latest Adobe® Reader® from the Adobe web site and install it.

"WJ-GXE500" or "GXE500" shown in the instructions and illustrations used in these operating instructions indicate the WJ-GXE500, WJ-GXE500E.

The screens used in these operating instructions show the case of NTSC model.

Refer to the readme file on the provided CD-ROM for further information including the dedicated software, its version, and compatible cameras.

## System requirements for a PC

CPU	Intel® Core™ 2 Duo 2.4 GHz or faster
Memory:	512 MB or more (A minimum of 1 GB memory is required when using Microsoft® Windows® 7 and Microsoft® Windows Vista®.)
Network Interface:	10BASE-T/100BASE-TX 1 port
Audio Interface:	Sound card (when using the audio function)
Monitor	Image capture size: 1 024 x 768 pixels or more Color: 24-bit True color or better
OS:	Microsoft® Windows® 7 Professional (64-bit) Microsoft® Windows® 7 Professional (32-bit) Microsoft® Windows Vista® Business SP1 (32-bit) Microsoft® Windows® XP Professional SP3
OS language:	English, French, Spanish*, German*, Italian*, Russian*
Web browser	Windows® Internet Explorer® 8.0 (Microsoft® Windows® 7 Professional (32-bit/64-bit)) Windows® Internet Explorer® 7.0 (Microsoft® Windows Vista® Business SP1 (32-bit)) Microsoft® Internet Explorer® 6.0 SP3 (Microsoft® Windows® XP Professional SP3)
Other	CD-ROM drive (It is necessary to read the operating instructions and use the software on the provided CD-ROM.) DirectX® 9.0c or later Adobe® Reader® (It is necessary to read the operating instructions on the provided CD-ROM.)

\* PAL model only

---

**Important:**

- When using a PC that does not meet the above requirements, displaying of images may become slower or the web browser may become inoperable.
  - Audio may not be heard if a sound card is not installed on a PC. Audio may be interrupted depending on the network environment.
  - Microsoft® Windows® XP Professional 64-bit Edition is not supported.
  - When using IPv6 for communication, use Microsoft® Windows® 7 or Microsoft® Windows Vista®.
- 

---

**Note:**

- Refer to "Notes on Windows Vista® / Windows® 7" (PDF) for further information about system requirements for a PC and precautions when using Microsoft® Windows® 7 or Microsoft® Windows Vista®.
- 

## Trademarks and registered trademarks

- Microsoft, Windows, Windows Vista, Internet Explorer, ActiveX and DirectX are either registered trademarks or trademarks of Microsoft Corporation in the United States and/or other countries.
- Intel and Intel Core are trademarks or registered trademarks of Intel Corporation in the United States and other countries.
- Adobe, the Adobe logo, and Reader are either registered trademarks or trademarks of Adobe Systems Incorporated in the United States and/or other countries.
- SDHC logo is a trademark.
- Other names of companies and products contained in these operating instructions may be trademarks or registered trademarks of their respective owners.

## Copyright

Distributing, copying, disassembling, reverse compiling, reverse engineering, and also exporting in violation of export laws of the software provided with this unit are expressly prohibited.

# Network security

As you will use this unit connected to a network, your attention is called to the following security risks.

- ① Leakage or theft of information through this unit
- ② Use of this unit for illegal operations by persons with malicious intent
- ③ Interference with or stoppage of this unit by persons with malicious intent

It is your responsibility to take precautions such as those described below to protect yourself against the above network security risks.

- Use this unit in a network secured by a firewall, etc.
- If this unit is connected to a network that includes PCs, make sure that the system is not infected by computer viruses or other malicious entities (using a regularly updated anti-virus program, anti-spyware program, etc.).
- Protect your network against unauthorized access by restricting users to those who log in with an authorized user name and password.
- Apply measures such as user authentication to protect your network against leakage or theft of information, including image data, authentication information (user names and passwords), alarm mail information, FTP server information and DDNS server information.
- Do not install this unit in locations where the unit or the cables can be destroyed or damaged by persons with malicious intent.

# Precautions

## **Refer installation work to the dealer.**

Installation work requires technique and experiences. Failure to observe this may cause fire, electric shock, injury, or damage to the product.

Be sure to consult the dealer.

## **Stop the operation immediately when something is wrong with this product.**

When smoke goes up from this product or the smell of smoke comes from this product, stop the operation immediately and contact your dealer.

Turn the power off immediately and contact qualified service personnel for service.

## **Do not attempt to disassemble or modify this product.**

Failure to observe this may cause fire or electric shock.

Consult the dealer for the repair or inspections.

## **Do not insert any foreign objects.**

This could permanently damage the apparatus. Turn the power off immediately and contact qualified service personnel for service.

## **Avoid placing receptacles that contain liquids such as water near this product.**

If liquid spills onto the unit, it may cause fire or an electric shock.

Unplug the power plug immediately and contact qualified service personnel for service.

## **Avoid placing the product in unstable positions.**

Injury or accidents may result if the product falls down or topples over.

## **Do not install or wire during lightning storms.**

Failure to observe this may cause fire or electric shock.

## **Avoid moist or dusty places to install this system.**

Failure to observe this may cause fire or electric shock.

## **Turn the power off when cleaning of this product.**

Failure to observe this may cause injury.

## **Do not block the openings for ventilation.**

Doing so can cause fire since it can raise the temperature inside this product high.

## **[Precautions for use]**

### **This product is designed to be used indoors. This product is not operable outdoors.**

### **To continue using with stable performance**

Do not use this product in hot and humid conditions for a long time. Failure to observe this causes component degradation resulting in life shortening of this product.

Recommended operating temperature: 35 °C {95 °F}

Do not expose this product to direct heat sources such as a heater.

### **Handle this product with care.**

Do not drop this product, nor apply shock or vibration to the product. Failure to observe this may cause trouble.

### **About the PC monitor**

When displaying the same image on the monitor for a long time, the monitor may be damaged. It is recommended to use a screen-saver.

### **When an error is detected, this product will restart automatically.**

When an error is detected, this product will restart automatically.

The unit will be inoperable for around 2 minutes after the restart just as when the power is turned on.

### **Product disposal/transfer**

Images saved on the SDHC/SD memory card may lead to personal information leakage.

When it is necessary to dispose or give this product to someone, even when for repair, make sure that there is no data on the hard disk drives.

### **Indication label**

Refer to the indication label on the bottom of this product for the equipment classification and power source, etc.

### **Cleaning this product body**

Turn the power off when cleaning this product. Do not use strong abrasive detergent when cleaning this product. Otherwise, it may cause discoloration. When using a chemical cloth for cleaning, read the caution provided with the chemical cloth product.

### **When the dirt is hard to remove, use a mild detergent and wipe gently.**

When the dirt is hard to remove, use a mild detergent and wipe gently. Then, wipe off the remaining detergent with a dry cloth.

### **Transmission interval**

Image transmission interval may become slow depending on the network environment, PC performance, shooting subject, access number, etc.

### **SDHC/SD memory card**

- Before inserting the SDHC/SD memory card, turn off the power of this product first. Otherwise, it may cause malfunction or damage data recorded on the SDHC/SD memory card. Refer to pages 18 and 19 for descriptions of how to insert/remove an SDHC/SD memory card.
- When using an unformatted SDHC/SD memory card, format it using this product. Recorded data on the SDHC/SD memory card will be deleted when formatted. If an unformatted SDHC/SD memory card or an SDHC/SD memory card formatted with other devices is used, the product may not work properly or performance deterioration

may be caused. Refer to the Operating Instructions (PDF) for how to format a SDHC/SD memory card.

- When some SDHC/SD memory cards are used with this product, the product may not work properly or performance deterioration may be caused. Use the SDHC/SD memory cards recommended in page 30.

### **Code label**

The code labels (accessory) are required at inquiry for trouble. Use caution not to lose these labels. It is recommended to paste one of the labels onto the CD-ROM case.

### **MPEG-4 Visual Patent Portfolio License**

This product is licensed under the MPEG-4 Visual Patent Portfolio License for the personal and non-commercial use of a consumer for (i) encoding video in compliance with the MPEG-4 Visual Standard ("MPEG-4 Video") and/or (ii) decoding MPEG-4 Video that was encoded by a consumer engaged in a personal and non-commercial activity and/or was obtained from a video provider licensed by MPEG LA to provide MPEG-4 Video. No license is granted or shall be implied for any other use. Additional information including that relating to promotional, internal and commercial uses and licensing may be obtained from MPEG LA, LLC. See <http://www.mpegla.com>.

### **AVC Patent Portfolio License**

This product is licensed under the AVC Patent Portfolio License for the personal and non-commercial use of a consumer to (i) encode video in compliance with the AVC Standard ("AVC Video") and/or (ii) decode AVC Video that was encoded by a consumer engaged in a personal and non-commercial activity and/or was obtained from a video provider licensed to provide AVC Video. No license is granted or shall be implied for any other use. Additional information may be obtained from MPEG LA, LLC. See <http://www.mpegla.com>.

# Precautions for Installation

**Installation work shall be performed in accordance with the technology standard of the electric installation.**

## **This product is designed to be used indoors.**

This product is not operable outdoors.

Do not expose this product to direct sunlight for hours and do not install the product near a heater or an air conditioner. Otherwise, it may cause deformation, discoloration and malfunction. Keep this product away from water and moisture.

## **Installation place**

- Place the unit correctly on a level surface.
- Do not place the unit in the following places:
  - Locations where it may get wet from rain or water splash
  - Locations where a chemical agent is used such as a swimming pool
  - Locations subject to humidity, dust, steam and oil smoke
  - Locations in a specific environment where a solvent or a flammable atmosphere exists
  - Locations where a radiation, an X-ray, a strong radio wave or a strong magnetic field is generated
  - Locations where corrosive gas is produced, Locations where it may be damaged by briny air such as seashores
  - Locations where the temperature is not within  $-10\text{ }^{\circ}\text{C}$  to  $+50\text{ }^{\circ}\text{C}$  ( $22\text{ }^{\circ}\text{F}$  to  $122\text{ }^{\circ}\text{F}$ ).
  - Locations subject to vibrations (This product is not designed for on-vehicle use.)
  - Locations subject to condensation as the result of severe changes in temperature

## **Be sure to remove this product if it is not in use.**

### **Radio disturbance**

When this product is used near TV/radio antenna, strong electric field or magnetic field (near a motor, a transformer or a power line), images may be distorted and noise sound may be produced.

### **PoE (Power over Ethernet)**

Use a PoE hub/device that is compliant with IEEE802.3af standard.

### **Router**

When connecting this product to the Internet, use a broadband router with the port forwarding function (NAT, IP masquerade).

Refer to the Operating Instructions (PDF) for further information about the port forwarding function.

### **SIGNAL GND terminal**

Connect this terminal with the SIGNAL GND terminals of the devices in the system for signal ground.

When operating this unit and the devices in the system without signal ground, oscillation or noise may be produced.

### **Heat dissipation**

To prevent this product from overheating, heed the following. Failure to observe this may cause fire or trouble.

- Do not block the ventilation openings. Maintain the unit periodically to prevent dust from blocking openings.

- Clear a space of more than 5 cm {1-31/32"} from both sides, the top, and the rear of the unit.  
Refer to page 16 for rack mount conditions.

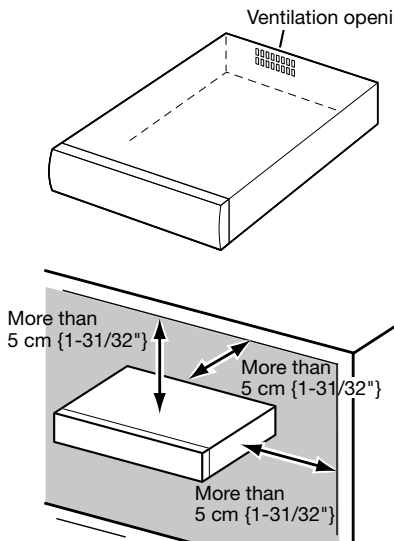

### To cut the power supply

Unplug the power cable (or the LAN cable when using PoE) from this product, or turn off the power-supply device connected to this product.

### Time & date setting

It is necessary to set the time & date before putting this product into operation.

In addition, depending on use environment, the time & date setting of this product may advance or delay.

To minimize the gap between the setting and the actual time, use the NTP server to update the time setting regularly.

Refer to the "Operating Instructions (PDF)" on the provided CD-ROM for descriptions of how to perform the settings of time & date and NTP server.

# Major operating controls and their functions

## Front view

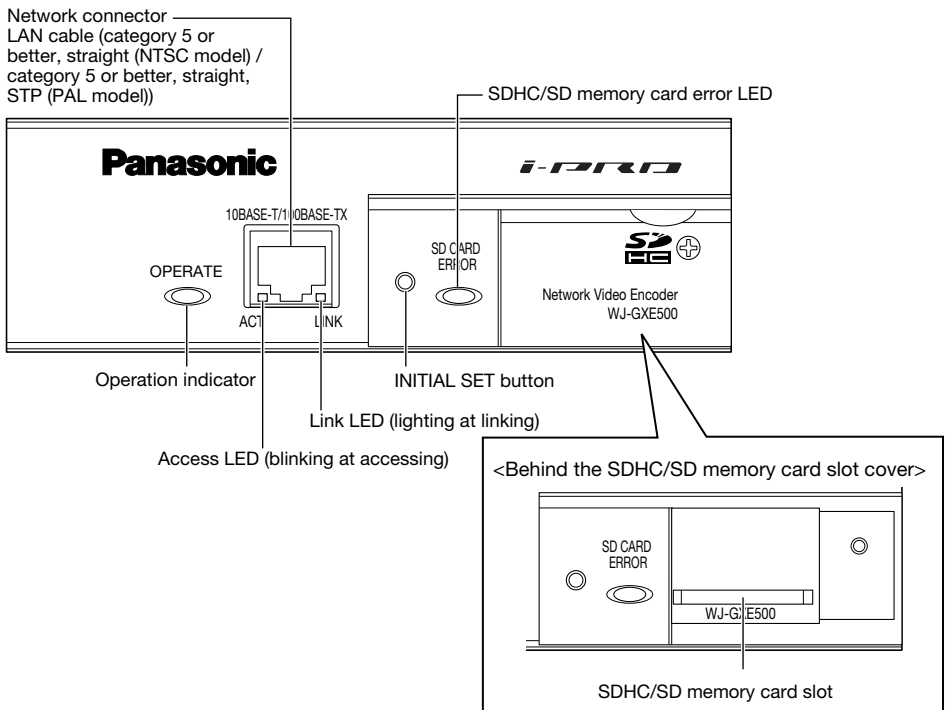

### About the [INITIAL SET] button

After turning off the power of the unit, turn on the power of the unit while holding down this button, and wait for around 5 seconds or more without releasing this button. Wait around 2 minutes after releasing the button. The unit will start up and the settings including the network settings will be initialized. Before initializing the settings, it is recommended to copy down the settings in advance.

# Rear view

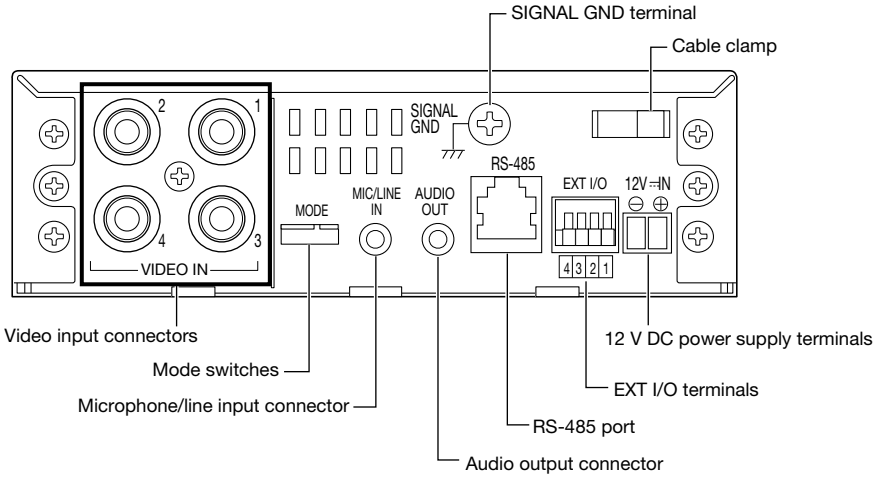

## Mode switches

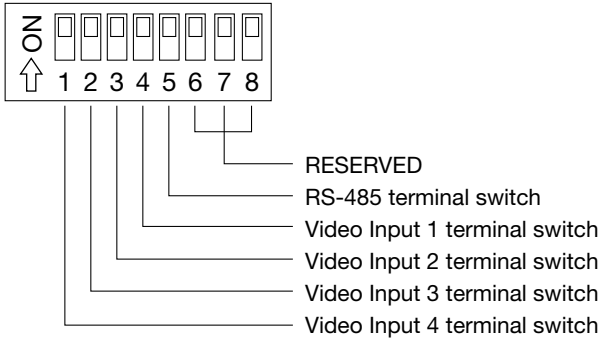

	ON	OFF	Default
Video Input terminal switches 1 to 4	Terminated	Not terminated	ON
RS-485 terminal switch	Terminated	Not terminated	ON

# Rack mounting

- 1 Remove the rubber feet (4 pcs.) on the bottom of the unit.

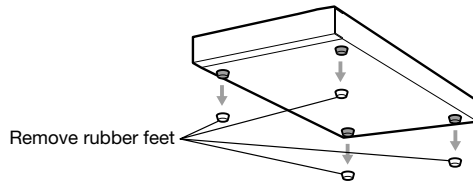

- 2 Install the rack mounting brackets (Option: Refer to the following.) on both sides of the unit. Using the bracket mounting screws (6 pcs.) for the rack mounting brackets, fix them firmly. When installing three units: Model No. WV-Q204/2S

- Rack mounting bracket x 2
  - Joint bracket x 4
  - Bracket mounting screws (M3 x 8: 6 pcs.)
  - Bracket mounting screws (Flat-head M3 x 6: 16 pcs.)
- Rack mounting screws (locally procured, diameter 5 tapping: 4 pcs.)

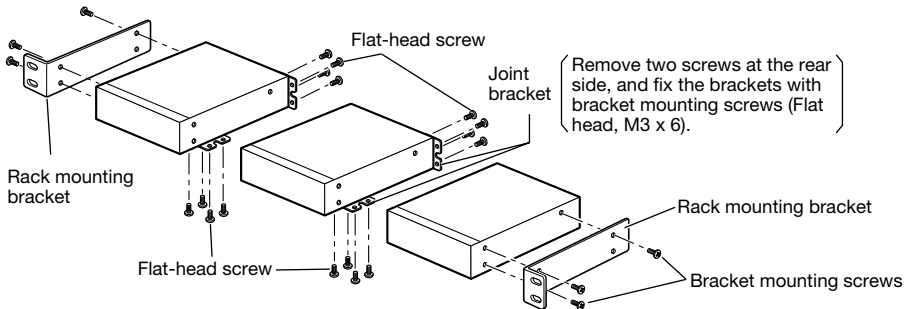

- 3** Install the unit in the rack.
- Using the rack mounting screws, fix them firmly.

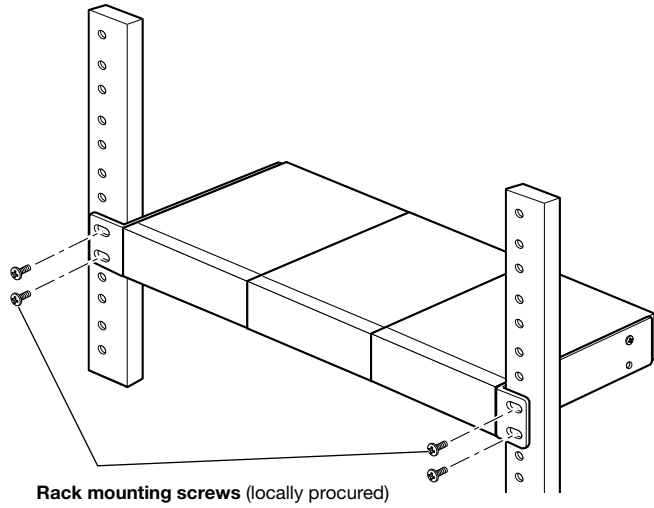

- Be sure to keep the temperature inside the rack below 30 °C {86 °F} when operating the units. Installing ventilation fan(s) in the rack is recommended especially when the rack is covered with front lids.

---

**Important:**

- When operating the units, keep the temperature inside the rack surely below 45 °C {113 °F}.
  - To prevent the unit from overheating, do not block the ventilation openings or slots in the cover.
-

# Insert/remove an SDHC/SD memory card

## Important:

- Before inserting the SDHC/SD memory card, turn off the power of the unit first.
- Insert an SDHC/SD memory card frontside up.
- Before removing the SDHC/SD memory card, select "Not use" for "SD memory card" on the [SD memory card] tab of "Basic" on the setup menu first.  
Turn off the power after "Not use" selection, and then unload the SDHC/SD memory card.  
(☞ Operating Instructions)

## How to insert an SDHC/SD memory card

- 1 Open the SDHC/SD memory card slot cover by loosening a screw.

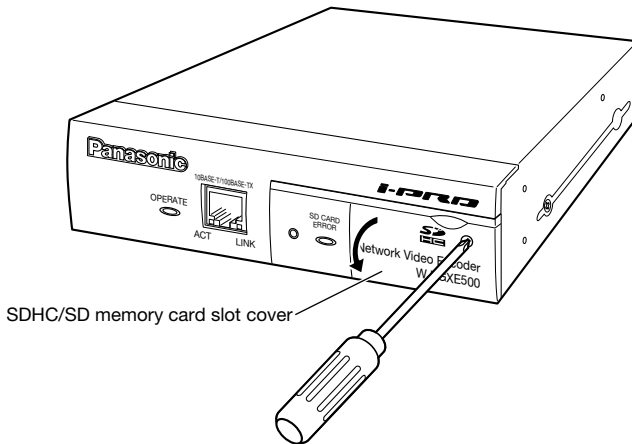

- 2 Insert an SDHC/SD memory card into the SDHC/SD memory card slot.

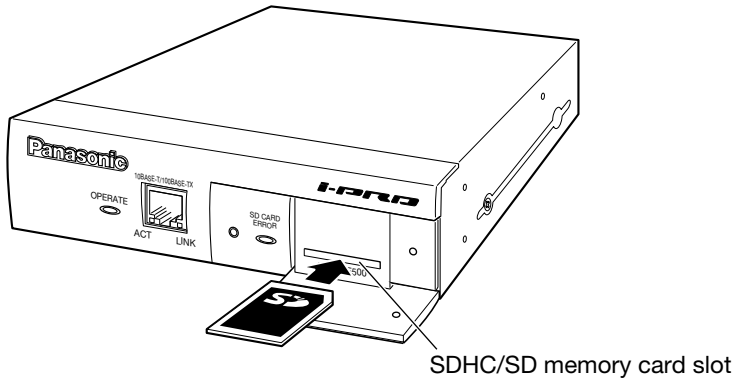

- 3 Close the SDHC/SD memory card slot cover and tighten the screw.

## How to remove the SDHC/SD memory card

- 1 Open the SDHC/SD memory card slot cover by following steps 1 of the "How to insert an SDHC/SD memory card" section.
- 2 Release the locked SDHC/SD memory card by pushing the card and then pull the SDHC/SD memory card from the slot.
- 3 Close the SDHC/SD memory card slot cover and tighten the screw.

# Connection

## Caution:

- ONLY CONNECT WJ-GXE500 TO 12 V DC CLASS 2 POWER SUPPLY.

Before starting the connection, turn off the power of this unit and connected devices.  
Before start the connection, prepare the required devices and cables.

- 1 Connect the coaxial cables to the video input connectors on the rear of the unit. Set the termination (75  $\Omega$ ) on or off with the mode switches as necessary. Video input connectors 1 to 4 are associated with Ch 1 to 4.

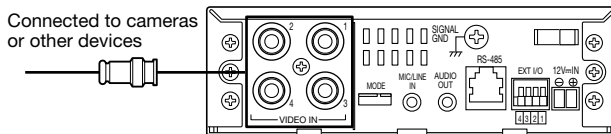

- 2 Connect the microphone to the microphone/line input connector (for use of the audio reception function).  
Input impedance: Approx. 2 k $\Omega$   
Recommended cable length: 1 m {3.3'} or less (for microphone input)  
10 m {32.81'} or less (for line input)  
Recommended microphone: Plug-in power type microphone (option)  
Connect a monaural mini plug ( $\varnothing$ 3.5 mm).
  - Supply voltage: 2.5 V $\pm$ 0.5 V
  - Recommended sensitivity of microphone: -48 dB  $\pm$ 3 dB (0 dB=1 V/Pa, 1 kHz)

---

## Important:

- Connect/disconnect the audio cables and turn on the power of the unit after turning off the power of the audio output devices. Otherwise, loud noise may come out from the speaker.
- 

- 3 Connect an external speaker with the amplifier to the audio output connector (for use of the audio transmission function).  
Connect a stereo mini plug ( $\varnothing$ 3.5 mm) (monaural output).
  - Recommended cable length: Less than 10 m {32.81'}

- 4** Connect an external device to the EXT I/O terminals.  
 When connecting an external device, remove 9 mm – 10 mm of the outer jacket of the cable and twist the cable core to prevent the short circuit first.

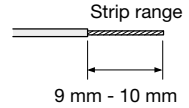

Specification of cable (wire): 22 AWG - 28 AWG

Single core, twisted

- \* Check whether the stripped part of the wire is not exposed and is securely connected.

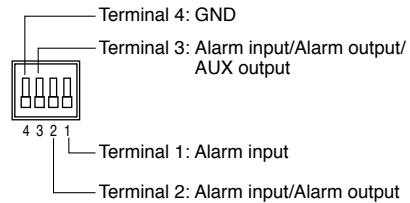

**Important:**

- Do not connect 2 wires or more directly to a terminal. When it is necessary to connect 2 or more wires, use a splitter.
- Connect an external device with verifying that the ratings are within the specifications above.
- When using the EXT I/O terminals as the output terminals, ensure they do not cause signal collision with external signals.

**<Ratings>**

- Alarm output  
 AUX output  
 Output specification: Open collector output (maximum applied voltage: 20 V DC)  
 Open: 4.5 - 5.5 V DC by internal pull-up  
 Close: Output voltage 1 V DC or less (50 mA or less)
- Alarm input  
 Input specification: No-voltage make contact input (4.5 - 5.5 V DC, internally pulled up)  
 OFF: Open or 4.5 - 5.5 V DC  
 ON: Make contact with GND (required drive current: 1 mA or more)

- 5 Connect the RJ11 modular cable to the RS-485 port.

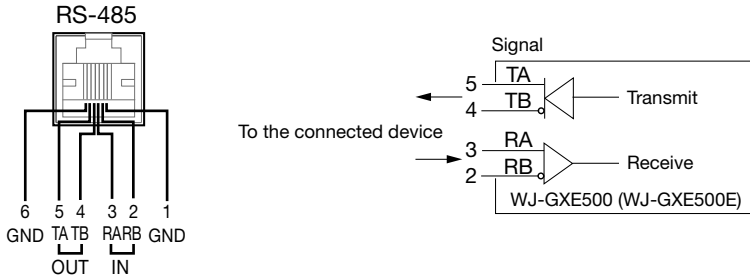

**Important:**

- The RS-485 connector of this unit is intended for the 4-wire communication. When connecting cameras for the 2-wire communication in the daisy chain, do as the following illustration describes.

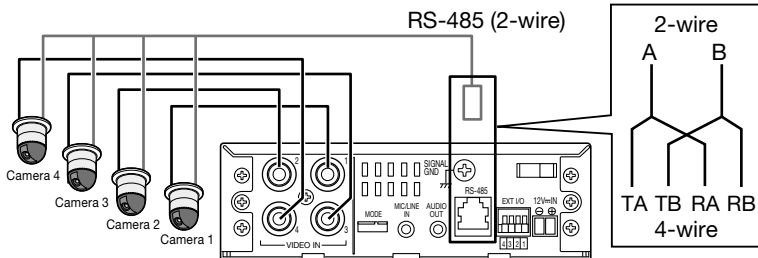

- When connecting cameras and units in the daisy chain, set the RS-485 terminal switch of the units at the connection ends to ON and other units to OFF. (→ page 15)

- 6 Connect a LAN cable (category 5 or better) to the network connector on the front of the unit.

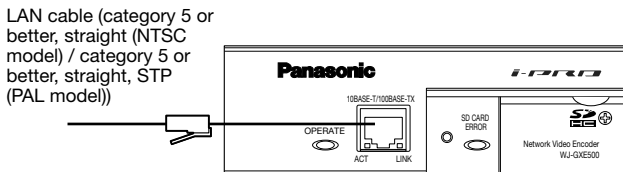

- 7 Connect the power cord.

**Important:**

- The power supply of 12 V DC shall be insulated against 120 V AC or 220 - 240 V AC.

## When using 12 V DC power supply

- ① Loosen the screw of the power cord plug (accessory).
- ② Connect the cable of the 12 V DC power supply to the power cord plug.  
Strip the end of the wire by 3 mm to 7 mm {1/8" to 9/32"}, and twist the stripped part of the wire sufficiently to avoid short circuit.  
Specification of cable (wire): 16 AWG - 28 AWG, single core, twisted  
\* Check whether the stripped part of the wire is not exposed and is securely connected
- ③ Tighten the screw of the power cord plug.
- ④ Connect the power cord plug to the 12 V DC power supply terminal on the rear of the unit.
- ⑤ Hold the power cable using the cable clamp.

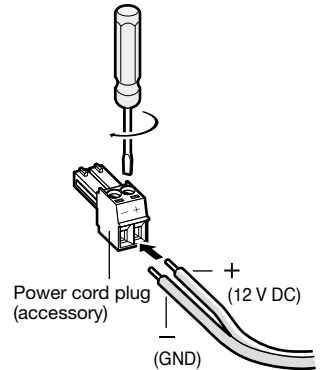
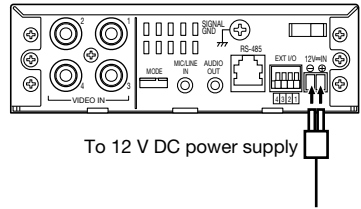

---

### Important:

- Be sure to use the power cord plug provided with this product.
  - Be sure to fully insert the power cord plug (accessory) into the 12 V DC power supply terminal. Otherwise, it may damage the unit or cause malfunction.
- 

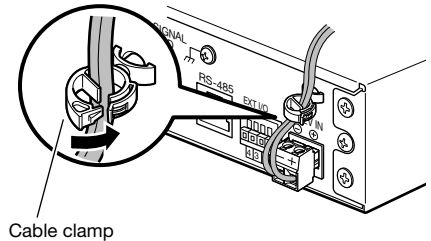

## When using PoE (IEEE802.3af compliant)

Connect a LAN cable (category 5 or better) between a PoE device (such as a hub) and the network connector of the unit.

---

### Important:

- Use all 4 pairs (8 pins) of the LAN cable.
  - The maximum cable length is 100 m {328.08'}.
  - Make sure that the PoE device in use is compliant with IEEE802.3af standard.
  - When connecting both the 12 V DC power supply and the PoE device for power supply, PoE will be used for power supply.
  - When disconnecting the LAN cable once, reconnect the cable after about 2 seconds.  
When the cable is quickly connected, the power may not be supplied from the PoE device.
-

# Connection example when connecting to a network using a PoE hub

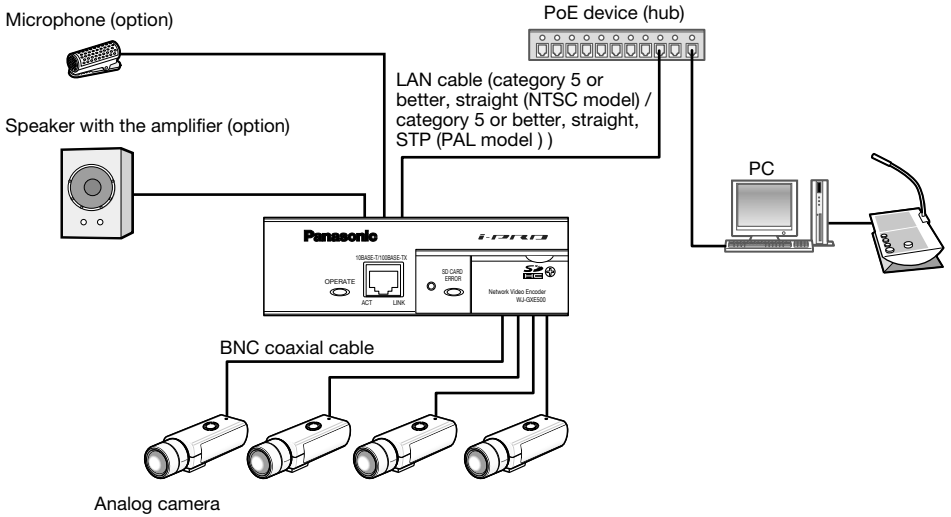

## <Required cable>

LAN cable (category 5 or better, straight (NTSC model) / category 5 or better, straight, STP (PAL model))

---

### Important:

- Use a switching hub or a router which is compliant with 10BASE-T/100BASE-TX.
  - Power supply is required for each unit. When using a PoE device (hub), 12 V DC power supply is unnecessary.
  - Refer to the readme file on the provided CD-ROM for further information about the supported models and versions of devices to be connected.
-

# Performing the network settings

## Install the software

Before installing the software, refer to the readme file on the provided CD-ROM first.

### Software included on the provided CD-ROM

- Panasonic IP setting software  
Configure the network settings of the unit. Refer to the following for further information.
- Viewer Software "Network Camera View4"  
It is necessary to install the viewer software "Network Camera Viewer4" to display images on a PC. Install the viewer software by double-clicking the "nwcvc4setup.exe" icon on the provided CD-ROM.

## Configure the network settings of the unit using the Panasonic IP setting software

It is possible to perform the network settings of the unit using the IP setup software on the provided CD-ROM.

When using two or more units, it is necessary to configure the network settings of each unit independently.

If the Panasonic IP setting software does not work, perform the network settings of the unit and the PC individually on the "Network" page of the setup menu. Refer to the Operating Instructions (PDF) for further information.

---

### Important:

- When using Microsoft® Windows Vista®, the "Windows Security Alert" window may be displayed when starting the IP setup software. In this case, disable "User Account Control" from the control panel.
  - For the security enhancement, the MAC address/IP address of the unit to be configured will not be displayed when around 20 minutes have passed after turning on the power of the unit. (when the effective period is set to "20 minutes" in the IP setup)
  - Panasonic IP setting software is inoperable in other subnets via the same router.
  - This unit cannot be displayed or set with an older version of the IP setup software (version 2.xx).
-

- 1 Start the Panasonic IP setting software.
- 2 Click the [IP setting] button after selecting the MAC address/IP address of the unit to be configured.

**Note:**

- When using a DHCP server, the IP address assigned to the unit can be displayed by clicking the [Refresh] button of the IP setting software.
- When a duplicate IP address is used, the corresponding MAC address/IP address will be displayed shaded.

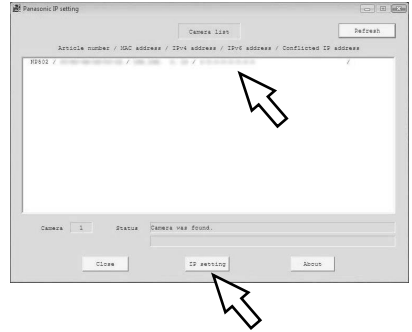

- 3 Complete each network setup item and click the [Apply] button.

**Note:**

- When using a DHCP server, it is possible to set "DNS" to "AUTO".

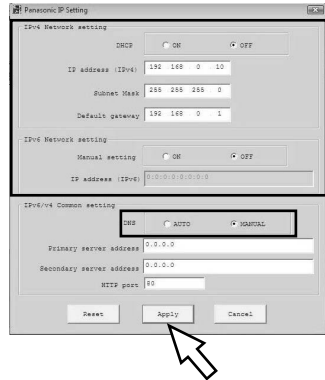

**Important:**

- It may take for around 2 minutes to complete to upload the settings to the unit after clicking the [Apply] button. The settings may be invalidated when the 12 V DC power supply is cut or when the AC adapter or the LAN cable is disconnected before completing the upload. In this case, perform the settings again.
- When using a firewall (including software), allow access to all UDP ports.

# Troubleshooting

## Before asking for repairs, check the symptoms with the following table.

Contact your dealer if a problem cannot be solved even after checking and trying the solution in the table or a problem is not described below.

Symptom	Cause/solution	Reference pages
<p><b>Power is not turned on.</b></p>	<p><b>When using DC power supply</b></p> <ul style="list-style-type: none"> <li>• Is 12 V DC power supply connect to the power supply terminal? → Check whether the connection is appropriately established.</li> </ul> <p><b>When using a PoE device for power supply</b></p> <ul style="list-style-type: none"> <li>• Are the PoE device and the network connector on the front of the unit connected using a 4-pair LAN cable? → Check whether the connection is appropriately established.</li> <li>• Depending on the PoE device, the power supply will stop when the demanded power exceeds its total power limit for all PoE ports. → Refer to the operating instructions of the PoE device in use.</li> </ul>	<p>23</p>
<p><b>The setup menu of the matrix switcher cannot be displayed.</b></p>	<ul style="list-style-type: none"> <li>• Non-interlace signals sometimes may not be transmitted to display setup menus. The setup menus of the matrix switchers such as WJ-SX550 Series are composed of non-interlace signals, which this unit sometimes cannot transmit.</li> </ul>	<p>—</p>

# Specifications

## ● Basic

Power source	12 V DC, PoE (IEEE802.3af compliant)
Power consumption	12 V DC: 500 mA, PoE: 6 W (Class 0 device)
Ambient operating temperature	-10 °C to +50 °C {14 °F to 122 °F}
Ambient operating humidity	Less than 90 %
Video input connectors	
NTSC model:	1 V [P-P]/75 Ω (BNC x 4), NTSC composite video signal
PAL model:	1 V [P-P]/75 Ω (BNC x 4), PAL composite video signal
EXT I/O terminals	Terminal 1: Alarm input Terminal 2: Alarm input/Alarm output Terminal 3: Alarm input/Alarm output/AUX output x1 each
Microphone/line input	ø3.5 mm monaural mini jack
(Associated with Video input Ch1)	Input impedance: Approx. 2 kΩ
For microphone input	Applicable microphone: Plug-in power type Supply voltage: 2.5 V ±0.5 V
For LINE input	Input level: Approx. -10 dBV
Audio output	ø3.5 mm stereo mini jack (monaural output)
(Associated with Video input Ch1)	Output impedance: approx. 600 Ω Line level
Serial port	RS-485, x1 (RJ11) (For external device control)
Dimensions	140 mm (W) x 44 mm (H) x 185 mm (D) {5-1/2" (W) x 1-3/4" (H) x 7-9/32" (D)} (excluding rubber feet and projections)
Weight	Approx. 1.0 kg {2.21 lbs.}

## ● Encoder

Video synchronization	Internal synchronization/Ch1 camera synchronization VD2 synchronization
Coaxial communication with cameras	pan/tilt/zoom/focus/preset positions/auto focus (When using Panasonic combination dome cameras)
Image recognition	
Face detection	On/Off (with the XML notification setting) (Ch 1 only)
Camera title on screen	Up to 16 characters (alphanumeric characters, marks) On/Off
VMD alarm	On/Off, 4 areas per channel available

## ● Network

Network	10BASE-T/100BASE-TX, RJ45 connector
Resolution	
NTSC model:	VGA mode H.264 VGA (640 × 480)/QVGA (320 × 240), max. 30 fps MPEG-4 VGA (640 × 480)/QVGA (320 × 240), max. 30 fps JPEG VGA (640 × 480)/QVGA (320 × 240), max. 30 fps D1 mode H.264 D1 (720 × 480), max. 30 fps MPEG-4 D1 (720 × 480), max. 30 fps JPEG D1 (720 × 480), max. 30 fps
PAL model:	VGA mode H.264 VGA (640 × 480)/QVGA (320 × 240), max. 25 fps MPEG-4 VGA (640 × 480)/QVGA (320 × 240), max. 25 fps JPEG VGA (640 × 480)/QVGA (320 × 240), max. 25 fps D1 mode H.264 D1 (720 × 576), max. 25 fps MPEG-4 D1 (720 × 576), max. 25 fps JPEG D1 (720 × 576), max. 25 fps
Image compression method*1	H.264/MPEG4 Image quality: Low/Normal/Fine Transmission type: Unicast/Multicast Bit rate: (Constant bit rate) 64kbps/128kbps/256kbps/384kbps/512kbps/768kbps/ 1 024kbps/1 536kbps/2 048kbps/3 072kbps/4 096kbps (Frame rate priority) NTSC model: 1fps/3fps/5fps/7.5fps/10fps/15fps/20fps/ 30fps PAL model: 1fps/3.1fps/4.2fps/6.25fps/8.3fps/12.5fps/ 20fps/25fps JPEG Image quality: 0 Super fine/1 Fine/2/3/4/5 Normal/6/7/8/ 9 Low (10 steps, 0 to 9) Transmission type: PULL/PUSH
Transmission interval	NTSC model: 0.1 fps - 30 fps PAL model: 0.08 fps - 25 fps (JPEG frame rate will be restricted when displaying both JPEG and H.264/MPEG-4 images.)
Audio compression method	G.726 (ADPCM) 32kbps/16kbps
Bandwidth control	Unlimited/64kbps/128kbps/256kbps/384kbps/512kbps/ 768kbps/1 024 kbps/2 048kbps/4 096kbps/8 192kbps

Protocol	IPv6: TCP/IP, UDP/IP, HTTP, RTP, FTP, SMTP, DNS, NTP, SNMP IPv4: TCP/IP, UDP/IP, HTTP, RTSP, RTP, RTP/RTCP, FTP, SMTP, DHCP, DNS, DDNS, NTP, SNMP
OS*2 *3	Microsoft® Windows® 7 Professional (64-bit) Microsoft® Windows® 7 Professional (32-bit) Microsoft® Windows Vista® Business SP1 (32-bit) Microsoft® Windows® XP Professional SP3
Browser	Windows® Internet Explorer® 8.0 (Microsoft® Windows® 7 Professional (32-bit/64-bit)) Windows® Internet Explorer® 7.0 (Microsoft® Windows Vista® Business SP1 (32-bit)) Microsoft® Internet Explorer® 6.0 SP3 (Microsoft® Windows® XP Professional SP3)
Maximum concurrent access number	14 (Depends on network conditions)
FTP client	Alarm FTP image transmission, FTP periodic transmission (When the FTP transmission is failed, backup on an optional SDHC/SD memory card is available.)
Multi-screen	Up to 16 camera images can be displayed simultaneously on a multi-screen.
Recommended SDHC/SD memory card (option)	Manufactured by Panasonic SDHC memory card: 4 GB, 8 GB, 16 GB, 32 GB SD memory card: 256 GB, 512 GB, 1 GB, 2 GB (miniSD card and micro SD card excluded)

\*1 Either H.264 or MPEG-4 is selectable.

\*2 Refer to "Notes on Windows Vista® / Windows® 7" (PDF) for further information about system requirements for a PC and precautions when using Microsoft® Windows® 7 or Microsoft® Windows Vista®.

\*3 When using IPv6 for communication, use Microsoft® Windows® 7 or Microsoft® Windows Vista®.

## Standard accessories

Installation Guide (this document) .....	1 pc.
Warranty card (NTSC model only) .....	1 pc.
CD-ROM*1 .....	1 pc.
Code label *2 .....	1 pc.
Power cord plug *3 .....	1 pc.

\*1 The CD-ROM contains the operating instructions (PDFs) and different kinds of tool software programs.

\*2 This label may be required for network management. The network administrator shall retain the code label.

\*3 This plug has been connected to the 12 V DC power supply terminal at the factory.

### Optional accessories

Rack mount bracket	WV-Q204/2S
--------------------	------------

## Information for Users on Collection and Disposal of Old Equipment and used Batteries



These symbols on the products, packaging, and/or accompanying documents mean that used electrical and electronic products and batteries should not be mixed with general household waste.

For proper treatment, recovery and recycling of old products and used batteries, please take them to applicable collection points, in accordance with your national legislation and the Directives 2002/96/EC and 2006/66/EC.

By disposing of these products and batteries correctly, you will help to save valuable resources and prevent any potential negative effects on human health and the environment which could otherwise arise from inappropriate waste handling.

For more information about collection and recycling of old products and batteries, please contact your local municipality, your waste disposal service or the point of sale where you purchased the items.

Penalties may be applicable for incorrect disposal of this waste, in accordance with national legislation.



### **For business users in the European Union**

If you wish to discard electrical and electronic equipment, please contact your dealer or supplier for further information.

### **[Information on Disposal in other Countries outside the European Union]**

These symbols are only valid in the European Union. If you wish to discard these items, please contact your local authorities or dealer and ask for the correct method of disposal.



### **Note for the battery symbol (bottom two symbol examples):**

This symbol might be used in combination with a chemical symbol. In this case it complies with the requirement set by the Directive for the chemical involved.

**Cd**

**For U.S. and Canadian fields:**

**Panasonic System Networks Company  
of America,  
Unit of Panasonic Corporation  
of North America**

[www.panasonic.com/business/](http://www.panasonic.com/business/)  
For customer support, call 1.800.528.6747  
Three Panasonic Way, Secaucus,  
New Jersey 07094 U.S.A.

**Panasonic Canada Inc.**

5770 Ambler Drive, Mississauga,  
Ontario, L4W 2T3 Canada  
(905)624-5010  
[www.panasonic.ca](http://www.panasonic.ca)

**For European and other fields:**

**Panasonic Corporation**

<http://panasonic.net>

Importer's name and address to follow EU rules:

Panasonic Testing Centre  
Panasonic Marketing Europe GmbH  
Winsbergring 15, 22525 Hamburg F.R.Germany