

# Panasonic

## Installation Guide

Included Installation Instructions

### Network Camera

Model No. **WV-X6531N / WV-X6511N / WV-S6530N**



WV-X6531N



- Before attempting to connect or operate this product, please read these instructions carefully and save this manual for future use.
- Before reading this manual, be sure to read the Important Information (included in the CD-ROM).
- For information about how to perform the settings and how to operate the camera, refer to the Operating Instructions on the provided CD-ROM.
- The model number is abbreviated in some descriptions in this manual.

#### For U.S. and Canada:

Panasonic Corporation of North America  
Two Riverfront Plaza, Newark, NJ 07102-5490  
http://business.panasonic.com/

Panasonic Canada Inc.  
5770 Ambler Drive, Mississauga, Ontario, L4W 2T3 Canada  
1-877-495-0580  
https://www.panasonic.com/ca/

#### For Europe and other countries:

Panasonic Corporation  
http://www.panasonic.com

Panasonic Corporation  
Osaka, Japan

Authorised Representative in EU:

Panasonic Testing Centre  
Panasonic Marketing Europe GmbH  
Winsbergring 15, 22525 Hamburg, Germany



© Panasonic Corporation 2017

avs0217-3068 PGQX2158WA Printed in China

#### WARNING:

- To prevent injury, this apparatus must be securely attached to the wall/ceiling in accordance with the installation instructions.
- All work related to the installation of this product should be made by qualified service personnel or system installers.
- The installation shall be carried out in accordance with all applicable installation rules.
- The connections should comply with local electrical code.
- This equipment is compliant with Class A of CISPR 32. In a residential environment this equipment may cause radio interference.
- Batteries (battery pack or batteries installed) shall not be exposed to excessive heat such as sunlight, fire or the like.

#### CAUTION:

- Any changes or modifications not expressly approved by the party responsible for compliance could void the user's authority to operate the equipment.
- The network camera is only intended for a connection to an ethernet or PoE+ network without routing to the outside plant.

For Canada  
CAN ICES-3(A)/NMB-3(A)

☐ : Direct current symbol

~ : Alternating current symbol

#### Disposal of Old Equipment and Batteries Only for European Union and countries with recycling systems



These symbols on the products, packaging, and/or accompanying documents mean that used electrical and electronic products and batteries must not be mixed with general household waste. For proper treatment, recovery and recycling of old products and used batteries, please take them to applicable collection points in accordance with your national legislation.

By disposing of them correctly, you will help to save valuable resources and prevent any potential negative effects on human health and the environment.

For more information about collection and recycling, please contact your local municipality. Penalties may be applicable for incorrect disposal of this waste, in accordance with national legislation.



#### Note for the battery symbol (bottom symbol)

This symbol might be used in combination with a chemical symbol. In this case it complies with the requirement set by the Directive for the chemical involved.

For U.S.A.

NOTE: This equipment has been tested and found to comply with the limits for a Class A digital device, pursuant to Part 15 of the FCC Rules. These limits are designed to provide reasonable protection against harmful interference when the equipment is operated in a commercial environment. This equipment generates, uses, and can radiate radio frequency energy and, if not installed and used in accordance with the instruction manual, may cause harmful interference to radio communications. Operation of this equipment in a residential area is likely to cause harmful interference in which case the user will be required to correct the interference at his own expense.

FCC Caution: To assure continued compliance, (example - use only shielded interface cables when connecting to computer or peripheral devices). Any changes or modifications not expressly approved by the party responsible for compliance could void the user's authority to operate this equipment.

The model number and serial number of this product may be found on the surface of the unit. You should note the model number and serial number of this unit in the space provided and retain this book as a permanent record of your purchase to aid identification in the event of theft.

Model No. \_\_\_\_\_  
Serial No. \_\_\_\_\_

## Important safety instructions

- 1) Read these instructions.
- 2) Keep these instructions.
- 3) Heed all warnings.
- 4) Follow all instructions.
- 5) Do not block any ventilation openings. Install in accordance with the manufacturer's instructions.
- 6) Do not install near any heat sources such as radiators, heat registers, stoves, or other apparatus (including amplifiers) that produce heat.
- 7) Only use attachments/accessories specified by the manufacturer.
- 8) Use only with the cart, stand, tripod, bracket, or table specified by the manufacturer, or sold with the apparatus. When a cart is used, use caution when moving the cart/apparatus combination to avoid injury from tip-over.
- 9) Unplug this apparatus during lightning storms or when unused for long periods of time.
- 10) Refer all servicing to qualified service personnel. Servicing is required when the apparatus has been damaged in any way, such as power-supply cord or plug is damaged, liquid has been spilled or objects have fallen into the apparatus, the apparatus has been exposed to rain or moisture, does not operate normally, or has been dropped.



## Troubleshooting

Before requesting service, refer to the Important Information (included in the CD-ROM) and "Troubleshooting" in the Operating Instructions (included in the CD-ROM) and confirm the trouble.

## Open Source Software

- This product contains open source software licensed under GPL (GNU General Public License), LGPL (GNU Lesser General Public License), etc.
- Customers can duplicate, distribute and modify the source code of the software under license of GPL and/or LGPL.
- Refer to the "readme.txt" file on the provided CD-ROM for further information about open source software licenses and the source code.
- Please note that Panasonic shall not respond to any inquiries regarding the contents of the source code.

## About notations

The following notations are used when describing the functions limited for specified models. The functions without the notations are supported by all models.

**X6531**: The functions with this notation are available when using the model WV-X6531N.

**X6511**: The functions with this notation are available when using the model WV-X6511N.

**S6530**: The functions with this notation are available when using the model WV-S6530N.

## About the user manuals

Product documentation is composed of the following documents.

- Installation Guide (this document and additional leaflet): Explains installation, mounting, cable connections, and network connections. This manual uses the WV-X6531N as an example in the explanations.
- Important Information (included in the CD-ROM): Provides basic information about the product.
- Operating Instructions (included in the CD-ROM): Explains how to perform the settings and how to operate this camera.

Adobe® Reader® is required to read these operating instructions on the provided CD-ROM.

When the Adobe Reader is not installed on the PC, download the latest Adobe Reader from the Adobe web site and install it.

The external appearance and other parts shown in this manual may differ from the actual product within the scope that will not interfere with normal use due to improvement of the product.

## Standard accessories

Installation Guide (this document and additional leaflet).....	1 pc.	Warranty card.....	1 pc.
CD-ROM*1.....	1 pc.	CD-ROM*1.....	1 pc.
IMPORTANT SAFETY INSTRUCTIONS.....	1 pc.	Code label*2.....	1 pc.

\*1 The CD-ROM contains the operating instructions and different kinds of tool software programs.  
\*2 This label may be required for network management. Use caution not to lose this label.

#### The following parts are used during installation procedures.

Cable cover.....	1 pc.	8P alarm cable.....	1 pc.
Attachment pipe.....	1 pc.	24 V AC power supply connector kit.....	1 set
Front/rear sunshields.....	1 set	(Power supply connector housing: 1 pc., Contact: 3 pcs.)	
Front/rear sunshields fixing screw.....	5 pcs.	Hexagon screw (M5)*3.....	5 pcs.
(of them, 1 for spare)		(of them, 1 for spare)	
Waterproof tape.....	1 pc.	Rain wash coating caution label.....	1 pc.
RJ45 waterproof connector cover.....	1 pc.		
RJ45 waterproof connector cap.....	1 pc.		

\*3 The screws are necessary when installing the camera on a separately sold mount bracket.

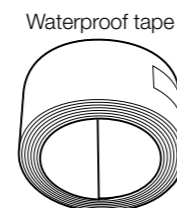

## Preparations

Please read "Precautions for installation" of "Important Information" in the provided CD-ROM closely before starting installation/connection of the camera.

### Other items that are needed (not included)

Prepare the required parts for each installation method before starting the installation. The following are the requirements for the various installation methods.

Installation method	Mounting screw	Minimum pull-out strength*1
<b>A) When hanging the camera from ceiling</b> Use the ceiling mount bracket (WV-Q121B*2).	M10 screws/ 4pcs.	1411 N {317 lbf}
<b>B) When installing the camera on a wall</b> Use the wall mount bracket (WV-Q122A*2).	M10 screws/ 4pcs.	823 N {185 lbf}

\*1 The minimum pull-out strength is the value per screw.

\*2 For details on procedure for attaching mount bracket and camera, read the operating instructions of each mount bracket.

#### IMPORTANT:

- Prepare four mounting screws (M10) to be mounted on ceiling and wall separately.
- Select screws according to the material of the location that the camera will be mounted to. In this case, wood screws and nails should not be used.
- If the mounting location such as plaster board is too weak to support the total weight, the area shall be sufficiently reinforced.

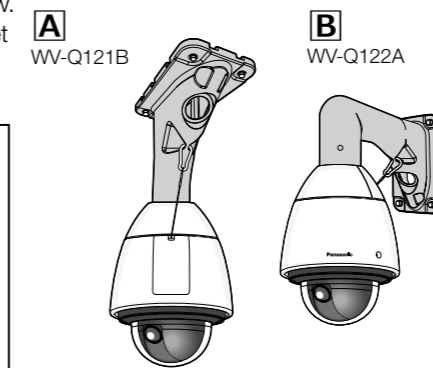

## Preparations before installation

### [1] Prepare the cables from camera side.

#### ◆ When the only necessary connection to camera is an Ethernet cable

Use only RJ45 network cable coming from camera. Do not remove the cable case. Use it as it is.

#### ◆ When using 24 V AC, EXT I/O device, or audio I/O device

Remove the cable case fixed by five screws on the upper part of camera and pull out power cable, audio I/O cable, and alarm I/O cable stored in it.

#### Note:

- Do not use the removed cable case and five screws.

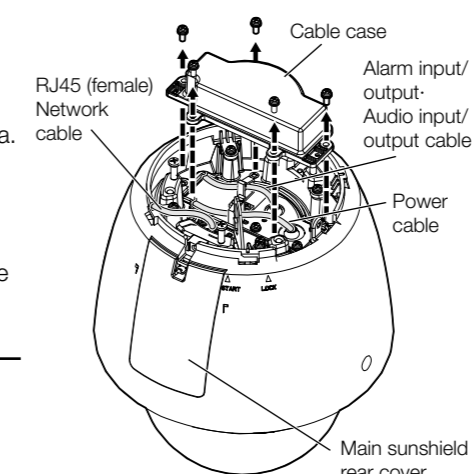

## Installation

The installation tasks are explained using 4 steps.

• Remove the camera using the reverse order of the installation procedures.

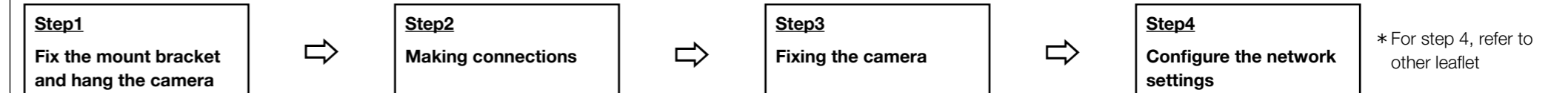

\* For step 4, refer to other leaflet

## Step 1 Fix the mount bracket and hang the camera

The following explains an example of installation using mount bracket (locally procured).

The right figure shows an example of the camera mounted on a ceiling with a mount bracket (locally procured).

When waterproofing, use waterproof material to fill in gaps and holes between the attachment pipe and the mount bracket.

### [1] Fix the attachment pipe (accessory) to the mount bracket (locally procured).

- ① Fix the attachment pipe to the mount bracket.
- ② Fill the gap between the mount bracket and attachment pipe with waterproof material (locally procured) such as silicon clay.
- ③ Pass the cables from the ceiling through the mount bracket.

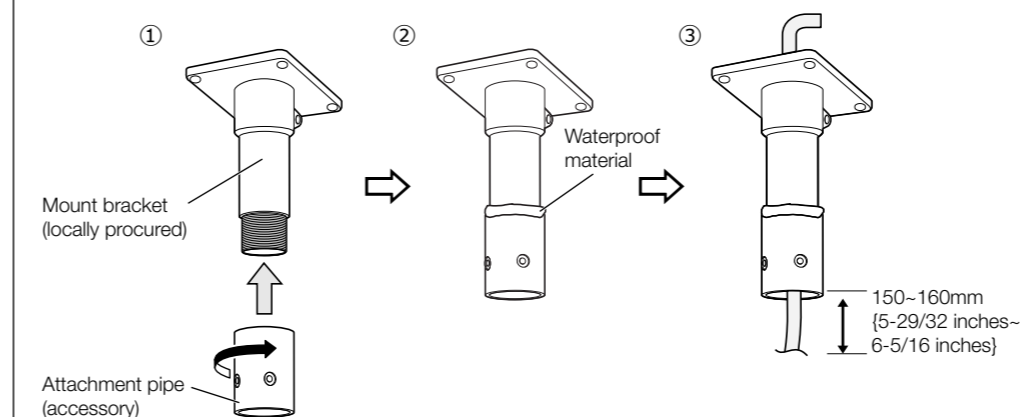

### [2] Fix the mount bracket (locally procured) on the installation surface.

Fix a mount bracket to the installation surface on the ceiling by using appropriate bolts, nuts or the like (locally procured).

#### IMPORTANT:

- After waterproofing the hole for fixing mount bracket and the port for pulling out the cable on the installation surface, fix the mount bracket on the installation surface.
- Adjust the length of cable from camera attachment port of attachment pipe to cable end to 150-160mm (5-29/32 inches-6-5/16 inches). (If the cable that is pulled out is too long, storage after wiring becomes difficult. Adjust the cable length carefully.)
- For the number of fixing screws and the minimum pull-out strength (per 1 pc.), refer to the operating instructions of mount bracket (locally procured).
- Ensure the minimum pull-out strength (per 1 pc.) that has sufficient allowance for total mass of mount bracket (locally procured), attachment pipe, and camera etc.

⇒Go to Step 1 [5].

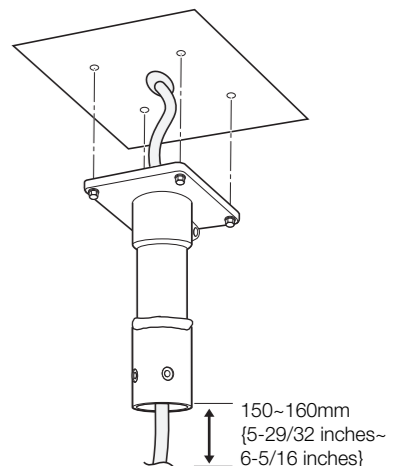

## Step1 Fix the mount bracket and hang the camera (continued)

◆ Here explains an example of installation on a wall using wall mount bracket (WV-Q122A). For detailed installation information and procedure, refer to operating instructions of each mount bracket.

### [3] Process the installation surface

Decide the attachment position and bore holes for screws or anchors on the wall and a hole for wiring as occasion demands.

### [4] Pass a cable into mount bracket and fix it on the installation surface

- Insert the cables coming from installation surface from rear surface of mount bracket to internal and pull them out from camera attachment port (cable cover attachment side).  
\* When passing the cables into mount bracket, take care not to apply unreasonable force to the cables.
- Apply waterproof treatment to the installation surface and the cap of the mount bracket backside.
- Attach the mount bracket to wall surface using fixing screws (4 pcs.) (M10: locally procured).

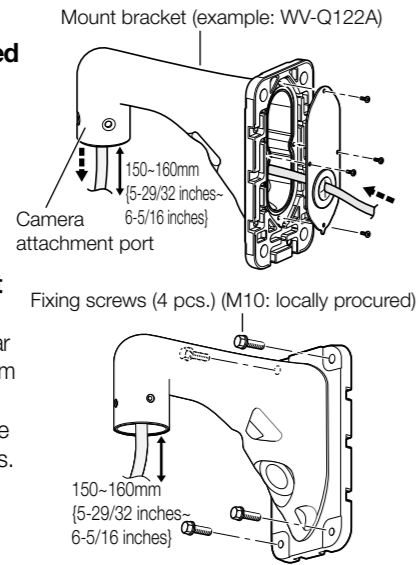

### IMPORTANT:

- After waterproofing the hole for fixing mount bracket, the port for pulling out the cable on installation surface, and the cap part on rear surface of mount bracket, fix the mount bracket on the installation surface.
- Fixing screw: Minimum pull-out strength (per 1 pc.)  
WV-Q121B 1411 N {317 lbf}  
WV-Q122A 823 N {185 lbf}
- Adjust the length of cable from camera attachment port of mount bracket to cable end to 150-160mm [5-29/32 inches-6-5/16 inches]. (If the cable that is pulled out is too long, storage after wiring becomes difficult. On the contrary, if it is too short, the cable cannot reach to the camera when installing the camera. Adjust the cable length carefully.)

◆ The following works are common to Q121B/Q122A (option) and mount bracket (locally procured).

### [5] Process the Ethernet cable (locally procured) and attach the waterproof connector cover and cap (accessory)

First pass the Ethernet cable through the RJ45 waterproof connector cap (accessory) and then through the RJ45 waterproof connector cover (accessory). Next, use a specialized tool (locally procured) to crimp the RJ45 plug (locally procured) to the end of the Ethernet cable.

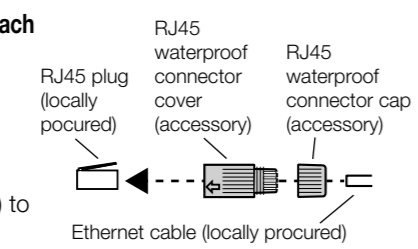

### IMPORTANT:

- Take care not to remove the rubber parts from inside the RJ45 waterproof connector cover (accessory).
- The maximum length of the Ethernet cable (locally procured) is 100 m, and the external dimensions of it are from ø5 mm [ø3/16 inches] to ø6.5 mm [ø1/4 inches].

## Step2 Making connections

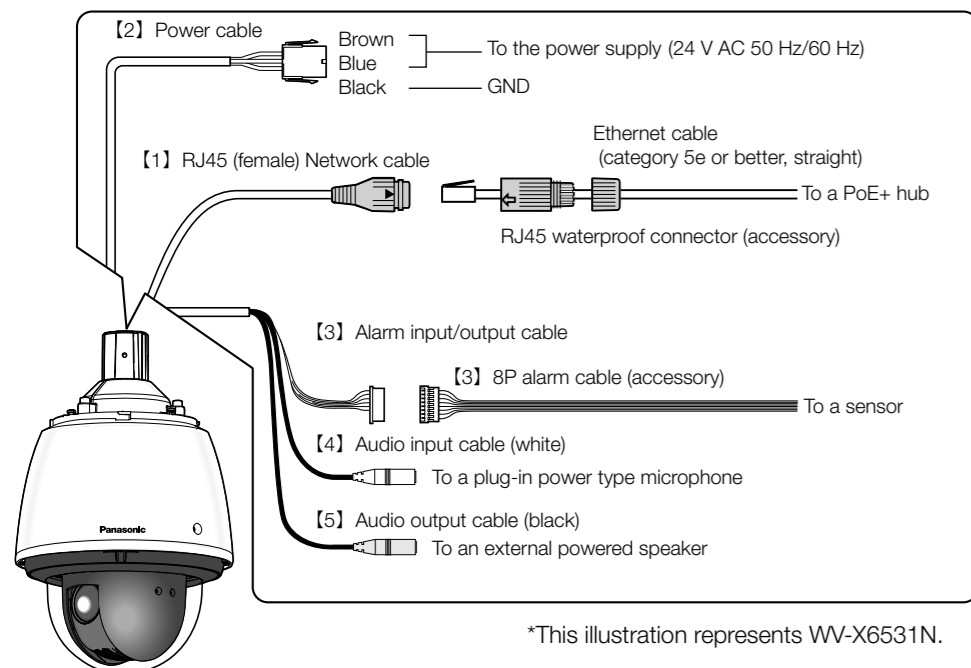

### [1] Connect an Ethernet cable (category 5e or better, straight) to RJ45 (female) network cable.

- Insert the RJ45 plug (locally procured) into the RJ45 waterproof jack connected to the camera.
- Connect the RJ45 waterproof connector cover (accessory) to the RJ45 waterproof jack and then rotate the RJ45 waterproof connector cover until the "←" marks align.
- Connect the RJ45 waterproof connector cap (accessory) to the RJ45 waterproof connector cover and rotate the RJ45 waterproof connector cap until there is no gap between it and the RJ45 waterproof connector cover.

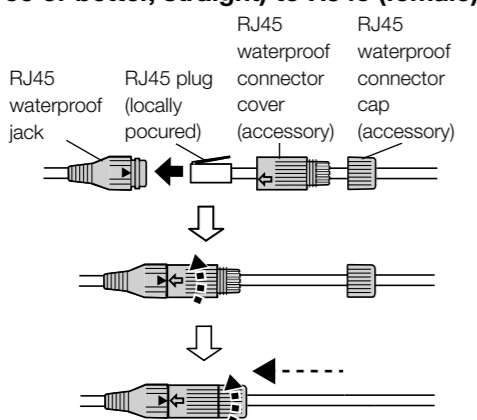

### IMPORTANT:

- If the procedure for the RJ45 waterproof connector (accessory) part is not correctly followed, the waterproofing may be compromised. Do not install the camera where the RJ45 waterproof connector is exposed to constant rain or moisture.
- When you remove the RJ45 waterproof connector, be sure to follow the reverse order of the connecting procedures. (The RJ45 waterproof jack may be damaged when you try to remove the RJ45 waterproof connector cover with its "←" mark matching "▶" mark of the RJ45 waterproof jack.)

## [6] Attach the cable cover (accessory)

- Fix the cable cover to WV-Q121B/WV-Q122A or attachment pipe using hexagon screws (4 pcs.) (M5: accessory). Adjust the orientation of cable cover so that the line part of cable cover faces front of the bracket.

### IMPORTANT:

- "Camera mounting screw (hexagon screw (M6))" included with WV-Q121B/WV-Q122A cannot be used. Use the "hexagon screw (M5)" included with the camera.
- Recommended tightening torque: 2.45 N-m {1.81 lbf-ft}

- Remove the tape as the installed auxiliary wire is temporarily fixed to the inside of the cable cover with tape.

## [7] Hang the camera at the installed auxiliary wire of the cable cover and fix the safety wire

- Move the camera to the installation location and hitch the installed auxiliary wire of the cable cover to the wire hook on the upper part of camera. Next, lower the wire stopper to prevent the installed auxiliary wire from coming off.
- Attach the safety wire of the camera to the wire hook section of mount bracket.

\* For the safety wire attachment position, refer to operating instructions of each mount bracket.

### Note:

- The camera is not fixed. Take care not to hit the camera against periphery (especially the dome cover).
- Retain a work space of 500 mm [1ft 7-11/16 inches] or more from the cable cover when you hang the camera from it.
- The installed auxiliary wire and the safety wire are designed assuming the only camera body is suspended. Do not apply other loads.

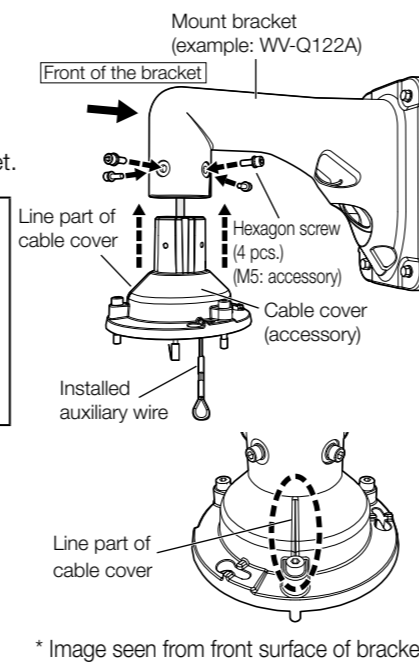

\* Image seen from front surface of bracket

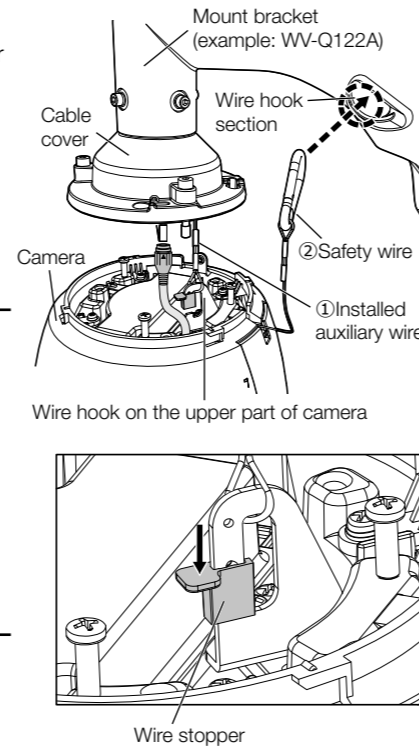

## Step2 Making connections (continued)

### [3] Connect 8P alarm cable (accessory) as occasion demands.

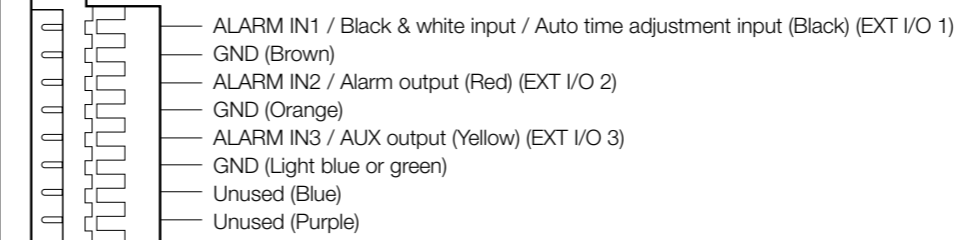

### Note:

- The default of EXT I/O terminals is "Off". Refer to the Operating Instructions on the provided CD-ROM for further information about the EXT I/O terminal settings.

### [4] Connect a microphone or external audio line to the audio input cable as occasion demands.

### [5] Connect a powered speaker to the audio output cable as occasion demands.

### Note:

- The audio output can be switched to monitor output. The default is "Audio". Refer to the Operating Instructions on the provided CD-ROM for descriptions of how to switch the output.
- If the audio output is used for the monitor output, connect a ø3.5 mm stereo mini connector (locally procured) to the wire as shown in the right figure and use it.

### [6] If you use a cable other than Ethernet cable, waterproof it.

The camera body is waterproof, but the cable ends and the inside of the mount bracket are not waterproof. Waterproof the connection part of each cable.

#### <Waterproof treatment>

Waterproof by using the waterproof tape (accessory) as shown in the right-hand figure.

### IMPORTANT:

- Stretch the tape by approx. twice (see the illustration) and wind it around the cable. Insufficient tape stretch causes insufficient waterproofing.

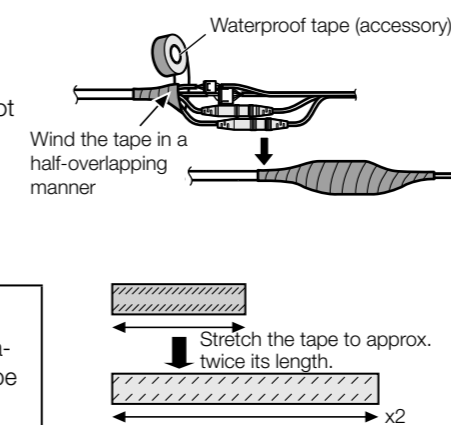

## Step3 Fixing the camera

### [1] Attach the camera to the cable cover (accessory).

- Make the Panasonic logo mark on the camera body face the front side and the main sunshield rear cover (where SD memory card is inserted) face the mount bracket side.
- Insert the positioning pins on the upper part of camera into cable cover attachment hole.
- Rotate the camera part in a clockwise direction when looking from the bottom and confirm it is temporarily fixed.
- Tighten it securely with 3 special screws (fixing screws) of the cable cover. Recommended tightening torque: 2.45 N-m {1.81 lbf-ft}

### Note:

- Special screw (fixing screw): As these are hexagon screws, use a hexagon wrench (locally procured) "for M6".
- Bend it to the inside of the cable cover to prevent the installed auxiliary wire and the wiring section from being caught in the periphery of the cable cover.

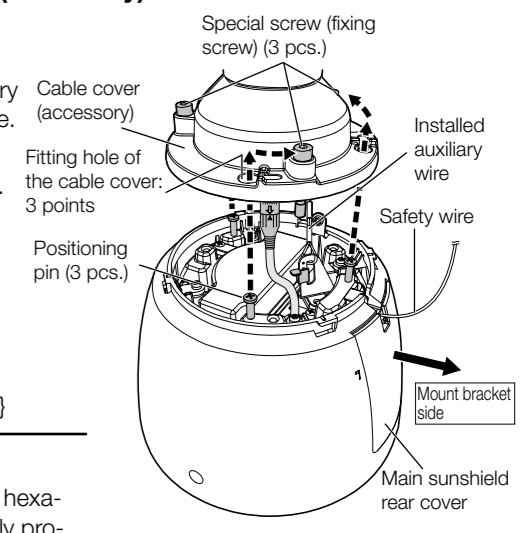

### [2] Attach the front/rear sunshields (accessory) to the camera.

- Put a finger on the dent of front/rear sunshields and unhook both sides to split it. One side is fixed with wire to prevent loss.

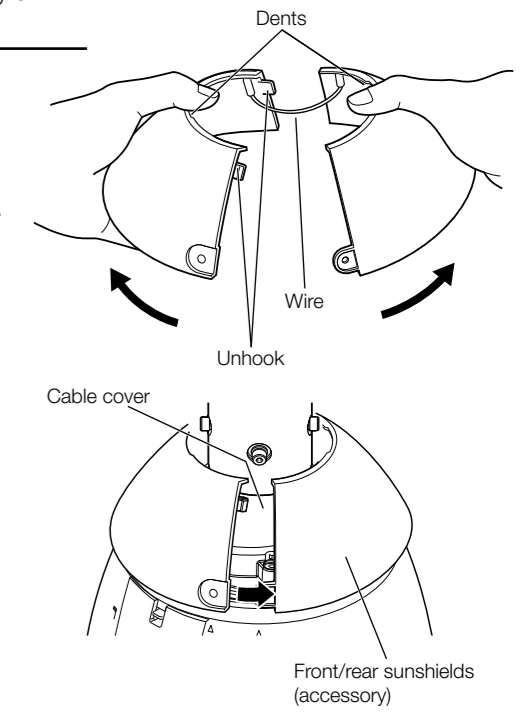

- Locate the front/rear sunshields to the position that covers the cable cover.

## Step2 Making connections

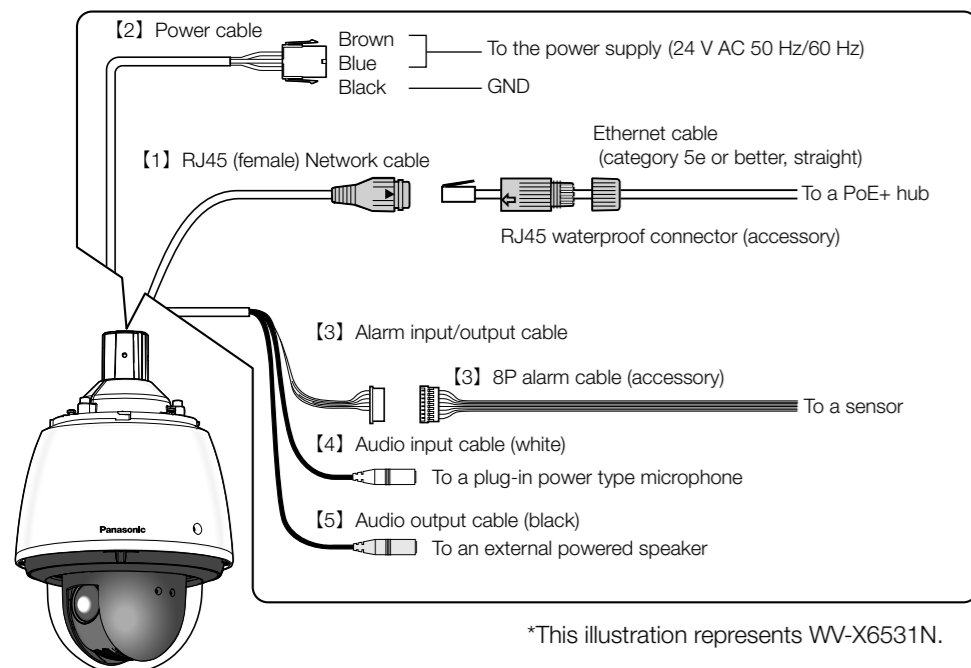

### [1] Connect an Ethernet cable (category 5e or better, straight) to RJ45 (female) network cable.

- Insert the RJ45 plug (locally procured) into the RJ45 waterproof jack connected to the camera.
- Connect the RJ45 waterproof connector cover (accessory) to the RJ45 waterproof jack and then rotate the RJ45 waterproof connector cover until the "←" marks align.
- Connect the RJ45 waterproof connector cap (accessory) to the RJ45 waterproof connector cover and rotate the RJ45 waterproof connector cap until there is no gap between it and the RJ45 waterproof connector cover.

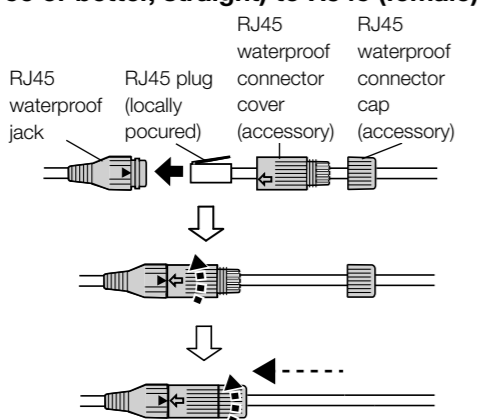

### IMPORTANT:

- If the procedure for the RJ45 waterproof connector (accessory) part is not correctly followed, the waterproofing may be compromised. Do not install the camera where the RJ45 waterproof connector is exposed to constant rain or moisture.
- When you remove the RJ45 waterproof connector, be sure to follow the reverse order of the connecting procedures. (The RJ45 waterproof jack may be damaged when you try to remove the RJ45 waterproof connector cover with its "←" mark matching "▶" mark of the RJ45 waterproof jack.)

## [2] Assemble 24 V AC connector kit (accessory) and connect it to the power cable of camera body as occasion demands.

- Recommended wire rod and array of pins of connector housing (accessory)

AWG size (stranded wire)	#24 (0.22 mm <sup>2</sup> )	#22 (0.33 mm <sup>2</sup> )	#20 (0.52 mm <sup>2</sup> )	#18 (0.83 mm <sup>2</sup> )
Wire length	20 m	30 m	45 m	75 m

### Power supply connector housing

Pin No.	Signal
1	24 V AC LIVE (Brown)
2	24 V AC NEUTRAL (Blue)
3	Ground (Black)
4	Not use

### [2] How to assemble the 24 V AC power supply connector kit

- Remove approx. 3 mm [1/8 inches] of the outer jacket of the cable and twist the cable core to prevent the short circuit first.
- Insert the tip of the cable into the point A of the contact (accessory), and hold the cable using the cable clamp.
- Procure either of the following tools for clamping.  
Molex manual clamp tool:  
57027-5000 (For UL1015),  
57026-5000 (For UL1007)
- After clamping the contact and the cable, insert the contact properly into the power supply connector housing.

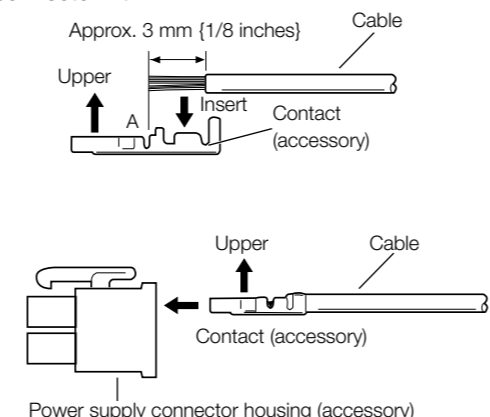

### Caution:

- A READILY ACCESSIBLE DISCONNECT DEVICE SHALL BE INCORPORATED TO THE EQUIPMENT POWERED BY 24 V AC POWER SUPPLY.
- ONLY CONNECT 24 V AC CLASS 2 POWER SUPPLY (UL 1310/CSA 223) or LIMITED POWER SOURCE (IEC/EN/UL/CSA 60950-1).
- ONLY CONNECT POWER OVER ETHERNET 54 V DC / PoE+ 54 V DC LIMITED POWER SOURCE (IEC/EN/UL/CSA 60950-1).

### IMPORTANT:

- The 24 V AC power supply shall be insulated from the commercial AC power.
- Be sure to use the 24 V AC power supply connector kit (accessory) provided with this product.
- After processing 24 V AC connector, actually connect it to the camera and ensure it operates normally before using it.
- Be sure to fully insert the 24 V AC power supply connector into the power cable. Otherwise, it may damage the camera or cause malfunction.
- When installing the camera, make sure that excessive force is not applied to the power cable.

## Step3 Fixing the camera (continued)

- Joint both sides of front/rear sunshields (accessory). First, hook the wire side, and then hook the other side.

### IMPORTANT:

- Joint both sides of the front/rear sunshields (accessory) before fitting in the main sunshield.
- Do not trap the safety wire inside.

- Fix the front/rear sunshields on the camera temporarily.

- Align the arrow (▽) with the arrow (△) of "START" on the main sunshield to embed it, and then rotate it toward arrow (△) of "LOCK" until it "clicks".

- Fix the front/rear sunshields on the camera using the front/rear sunshields fixing screw (accessory). Recommended tightening torque: 0.72 N-m {0.53 lbf-ft}

### Note:

- When removing the front/rear sunshields (accessory), perform steps ①-⑤ in the reverse order.

- When the camera has been installed, remove the protection sheet from the dome cover. After removal, be sure not to touch the clear part of the dome cover.

- Turn on the power supply of camera and check the screens of camera following Step 4 "Configure the network settings" and adjust the angular field of view. For details on adjustment of angular field of view of camera, refer to Operating Instructions on the provided CD-ROM.

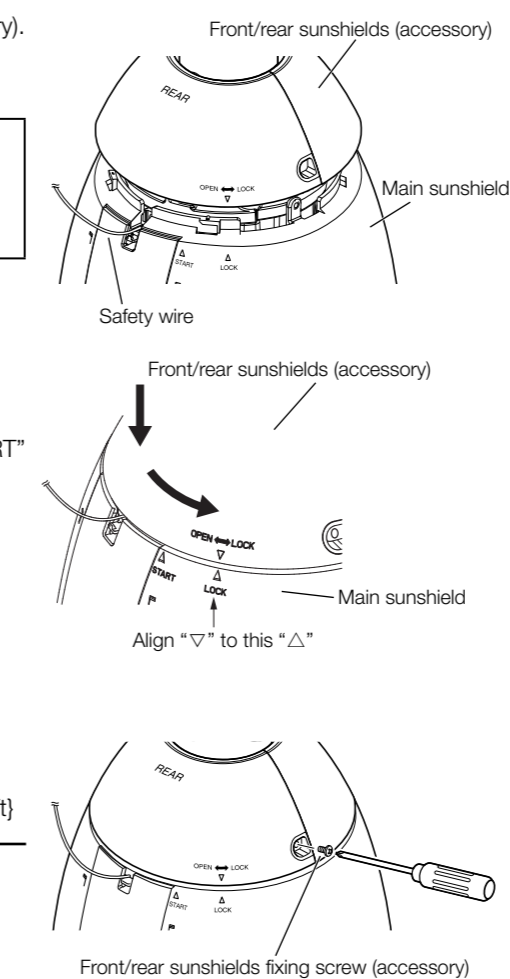

## Precautions

- Attach the "Rain wash coating caution label" carried by the camera to the surface of the camera (Refer to the illustration below).

请贴在本产品的侧面。  
Please put on the side of the product.  
製品外觀などに貼付けてください。



## Live indicator

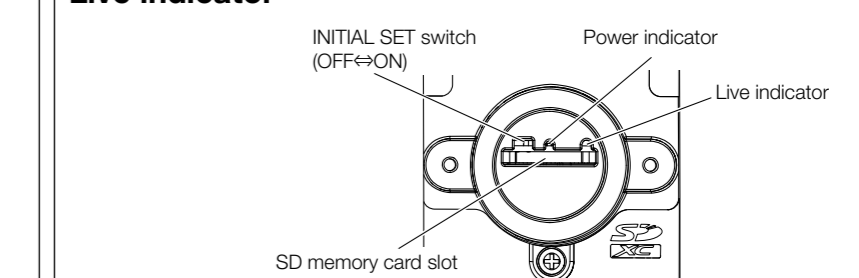

### The live indicator will light or blink as follows depending on the camera status.

Camera operation status	Live indicator status
When the power is turned on	Before the network connection is established Lights orange → Lights off → Blinks orange → Lights orange When the network connection is established Lights orange → Lights off → Blinks orange → Blinks green → Lights green
During the standby or connection (Cable is not connected.)	Lights orange
During the standby or connection (Cable is connected.)	Lights green
During the upgrade process	Blinks orange
Initialization (When the network connection is established)	Lights orange → Lights off → Blinks orange → Lights orange → Blinks orange → Blinks green → Lights green
Port forwarding error caused by the UPnP function	Blinks orange (in 2 seconds intervals (on for 1 second / off for 1 second))
Trouble happening on the camera	Blinks red
Failure in writing data on the SD memory card	Lights red